

An Open-Source-Based Testbed and Experiment for 5G Mobile Networks

Yoseop Ahn*, Yiwen Shen*, and Jaehoon (Paul) Jeong*

* Department of Computer Science & Engineering,
Sungkyunkwan University, Suwon, Republic of Korea
Email:{ahnjs124, chrisshen, pauljeong}@skku.edu

Abstract—This paper introduces a testbed for 5G mobile network that is able to integrate an intent-based network management and automation function. We use two Universal Software Radio Peripheral (USRP) devices as the radio frequency (RF) front-ends for user equipment (UE) side and radio access network (RAN) side, respectively. By using an intent-based networking (IBN) controller, an IBN user (e.g., a network administrator) can send an intended network configuration and policy toward the 5G core (5GC) networks. Inside the IBN controller, an intent is translated into the corresponding network policy by several functions: extraction, conversion, and generation. The constructed testbed uses several open-source software, such as Open5GS for 5GC networks and srsRAN for radio functions on both the UE and RAN sides. We conducted a primary connection test for a UE and a 5GC network, which demonstrates that the testbed is ready for the future research and experiment.

Index Terms—5G core networks, intent, 5G testbed, gNodeB, USRP.

I. INTRODUCTION

In contrast to 4G mobile networks, 5G mobile networks represent a groundbreaking evolution characterized by elevated speeds, utilization of high-frequency bands, broader bandwidth, extensive device connectivity, reduced energy consumption, and enhanced intelligence. However, the ability to discern a user intent and fully automate network management is highly dependent on the integration of intelligence [1], [2]. Intent-based 5G networks can substantially increase the efficiency and performance of mobile networks. As a result, it will improve services in different domains, e.g., smart city, virtual reality and augmented reality, and autonomous vehicles.

Therefore, we introduce a testbed for 5G mobile network testbed that is capable of integrating an intent-based network management and automation function. We use two Universal Software Radio Peripheral (USRP) devices as the radio frequency (RF) front-ends for the user equipment (UE) and the radio access network (RAN), respectively. Through an intent-based networking (IBN) controller, an IBN user (e.g., a network administrator) can send an intended network configuration and policy toward the 5G core (5GC) networks. An intent is defined as a configuration to request what goal is achieved (i.e., declarative command) rather than how a goal is achieved (i.e., imperative command) [3]. The intent can specify designated requirements for different network performances in different services, such as an IoT data service and an extended reality (XR) service. Inside the IBN controller, the intent is

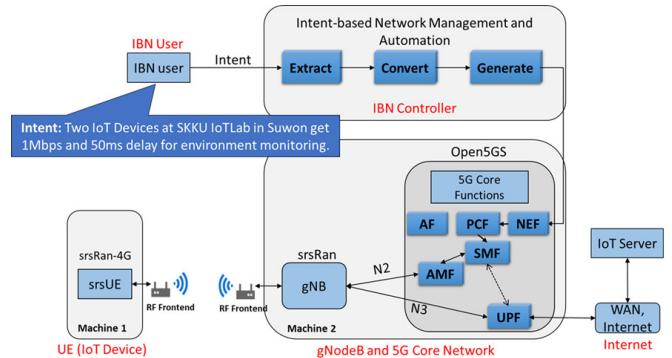

Fig. 1. Architecture of the 5G Core Network with Intent-Based Network Management and Automation

translated into the corresponding network policy by several functions: extraction, conversion, and generation.

The translated network policy is forwarded into a network exposure function (NEF) in the 5GC networks, which selects the internal functions to manipulate the network policy. The constructed testbed uses several open-source software, such as Open5GS for 5GC networks and srsRAN for radio functions on both the UE and the RAN sides. We conducted a primary connection test for a UE and a 5GC network, which demonstrates that the testbed is ready for the future research and experiment.

The remaining of this paper is structured as follows. Section II describes the architecture of the proposed intent-based network management and automation for 5G networks. Section III demonstrates a communication experiment between a UE and a 5GC network in the constructed testbed. Section IV concludes this paper along with future work.

II. ARCHITECTURE OF 5G TESTBED

This section introduces an architecture of 5G testbed of a 5G Core Network with the intent-based network management and automation. The intent-based 5G network consists of an IBN user, IBN controller, gNodeB, and 5G core network. The IBN user transfers an intent to the IBN controller that controls and monitors its system elements in an IBN context, as well as generates the network policy corresponding to the intent. The IBN controller can convert a user intent to the corresponding network policy. The extraction function verifies

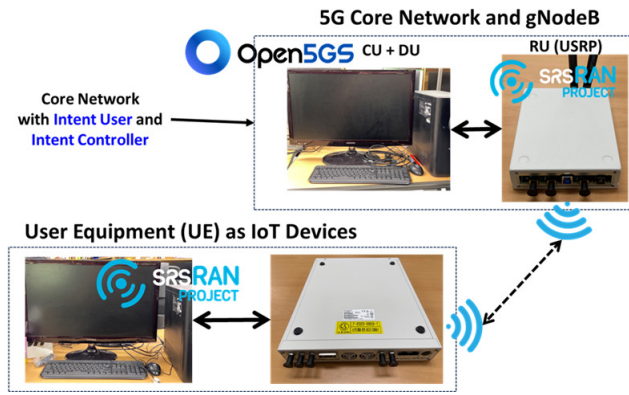

Fig. 2. SKKU 5G Testbed with USRP

the intent given by the IBN user and extracts the data. The conversion function transforms the extracted intent data to the matched policy data and chooses the network functions (NFs) to process the policy. The generation function produces a network policy to be delivered to the NFs [4]. An intent from an IBN user can be expressed in a form of a YAML document [3].

Fig 1 shows the architecture of the proposed testbed of intent-based 5G mobile network. For the 5GC network, the Access and Mobility Function (AMF) and User Plane Function (UPF) are the main parts of this architecture [5]. AMF handles a UE authenticated through Unified Data Repository (UDR) on a registered user access database. That is, when trying to access on 5G network, a UE shall go through an authentication procedure. If not registered on the database, the UE cannot access the 5G networks. For the UPF, it is to forward a UE's data packets to the external data networks (i.e., Internet). It ensures that the data packets reach their intended destination efficiently. Through the process of AMF and UPF, the UE can communicate with the 5GC network through a gNodeB [6].

III. TESTBED AND EXPERIMENT

We have built a testbed that has a UE, a gNodeB, and a 5G core network with USRP as shown in Fig. 2. The testbed can let the UE communicate with the 5G core network through gNodeB. The detailed configuration and experiment is described as follows.

Two computers were used to build the testbed where one is for the gNodeB and 5G Core Network, and the other is for the UE (e.g., IoT device) as shown in Fig. 2. The following configuration is made to build our testbed.

- Connect the USRP on each desktop (UE and gNodeB) through USB 3.0 and install all dependencies and drivers to handle the USRP on Linux [7]
- Install Open5GS [8], srsRAN22.04 [9], MongoDB, and the necessary dependencies.
- Add the Subscriber Identity Module (SIM) information (e.g., imsi, key, and opc) on the UE's USRP to communicate on 5G network.

- Register SIM information of the UE device on Open5GS configuration and change the IP addresses of AMF and UPF to connect USRP with UE through 5G network.
- Modify the configuration files (e.g., enb.conf and rr.conf) in srsRAN of gNodeB to connect to the 5GC network.
- Create the TUN device with the interface name "ogstun" on the gNodeB and 5GC network [10].
- Connect UE with 5G network and start the communication between gNodeB and UE.

After the above process, we can check the speed and delay of the link between the UE and the 5GC network.

IV. CONCLUSION

This paper introduced a testbed for 5G mobile network consisting of a gNodeB, a 5G core network, and a UE. We built the testbed using USRP to make gNodeB to communicate with UE through 5G network and to check the communication speed and delay. As future work, our objective is to create and deploy efficient solutions to convey network intent into network policies, optimizing the management of processes within 5G networks. Also, we will build an intent-based management system for IoT devices in 5G networks.

ACKNOWLEDGMENTS

This work was supported by the Ministry of Science and ICT (MSIT), Korea, under the Institute for Information & Communications Technology Planning & Evaluation (IITP)(No. 2022-0-01015, Development of Candidate Element Technology for Intelligent 6G Mobile Core Network). This work was supported in part by the IITP grant funded by the Korea MSIT (No. 2022-0-01199, Regional strategic industry convergence security core talent training business). Note that Jaehoon (Paul) Jeong is the corresponding author.

REFERENCES

- [1] A. Ghosh, A. Maeder, M. Baker, and D. Chandramouli, "5g evolution: A view on 5g cellular technology beyond 3gpp release 15," *IEEE access*, vol. 7, pp. 127 639–127 651, 2019.
- [2] "System Architecture for the 5G System (5GS)," September 2022. [Online]. Available: <https://portal.3gpp.org/desktopmodules/Specifications/SpecificationDetails.aspx?specificationId=3554>
- [3] 3GPP, "Management and orchestration; Intent driven management services for mobile networks;" 3rd Generation Partnership Project (3GPP), Technical Specification (TS) 28.312, September 2023, version 18.1.1. [Online]. Available: <http://www.3gpp.org/DynaReport/28312.htm>
- [4] J. P. Jeong, Y. Ahn, Y. Kim, and J.-S. Park, "Intent-Based Network Management Automation in 5G Networks;" *draft-jeong-nmrg-ibn-network-management-automation-03*, Nov. 2023.
- [5] M. A. Garcia-Martin, M. Gramaglia, and P. Serrano, "Network automation and data analytics in 3gpp 5g systems," *IEEE Network*, 2023.
- [6] Q. Tang, O. Ermis, C. D. Nguyen, A. De Oliveira, and A. Hirtzig, "A systematic analysis of 5g networks with a focus on 5g core security," *IEEE Access*, vol. 10, pp. 18 298–18 319, 2022.
- [7] "Building and Installing the USRP Open-Source Toolchain on Linux," 2023. [Online]. Available: [https://kb.ettus.com/Building_and_Installing_the_USRP_Open-Source_Toolchain_\(UHD_and_GNU_Radio\)_on_Linux](https://kb.ettus.com/Building_and_Installing_the_USRP_Open-Source_Toolchain_(UHD_and_GNU_Radio)_on_Linux)
- [8] "Open5Gs Installation and building guide Documentation," 2023. [Online]. Available: <https://open5gs.org/open5gs/docs/guide/02-building-open5gs-from-sources>
- [9] "srsRAN Project Installation and guide Documentation," 2023. [Online]. Available: <https://docs.srsran.com/projects/project/en/latest>
- [10] (2002) Universal tun/tap driver. [Online]. Available: <https://vtun.sourceforge.net/>